



DHI SOLUTION

WATER AND ENERGY – SAVINGS AND REUSE

Increased productivity and reduced environmental impact

Increased productivity and enhanced sustainability in industries are key competitive factors. For water consuming industries, a constant effort to reduce the consumption of water, energy and chemicals in production processes is an important measure to stay competitive or gain increased competitiveness. We have the expertise to support the industry in all phases of cleaner production measures, with respect to water-based production processes.

CHALLENGES IN INDUSTRIAL PRODUCTION

The pressure on natural resources is escalating, resulting in increased costs for purchase of water, energy and chemicals. At the same time, environmental considerations in terms of public health, recreational use, flora and fauna diversity and climate changes result in greater restrictions and higher costs related to industrial emissions. Furthermore, industries are increasingly looking for a 'green image'. This compounds the need to minimise the environmental impact of industrial production activities.

MEETING THE CHALLENGES

The consumption of energy, water, chemicals and other resources can be substantially reduced by optimising processes and technologies. This requires an in-depth understanding of various processes – both from a technological and managerial point of view. Production is also influenced by legislation and regulations such as EU directives.

SERVICES TO INDUSTRY

In the recent past, we've assisted the industry in meeting these challenges, through participation in a large number of cleaner production projects. Such projects may include some or all of the following elements:

- Audits with a focus on production processes and environmental issues

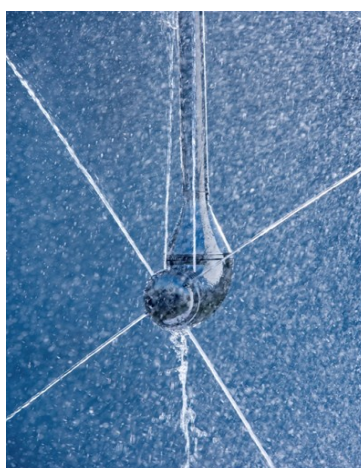

Many industries can optimise their water-using processes. The Sanijet (shown above) for instance, is used for cleaning in the food, beverage, pharmaceutical and biochemical industries. The result: financial savings and reduced environmental impacts. Photo: © Alfa Laval

SUMMARY

CLIENT

- Food and beverage industry
- Pharmaceutical industry
- Refining and petrochemical plants
- Other water and energy intensive industries

CHALLENGE

- Increasing pressure on water resources
- Growing demand for reducing CO₂ and water footprint
- Rising demand for cost-effective production
- Need to comply with stricter discharge regulations

SOLUTION

- Auditing, mapping and monitoring of processes and technologies followed by simulation of water reuse scenarios
- Recommendations regarding selection or testing of new processes and technology
- Support in negotiations with authorities

VALUE

- Saving on water and energy cost and reduced environmental impact
- Less dependency on access to water resources
- Facilitation of Corporate Social Responsibility efforts
- Compliance with increasingly strict regulations

- Mapping and visualisation of water sources, including flow water quality
- Planning and execution of measuring, sampling and analysis campaigns to compensate for the lack of data availability
- Preparation of reuse scenarios (if relevant) by using model-based process simulations

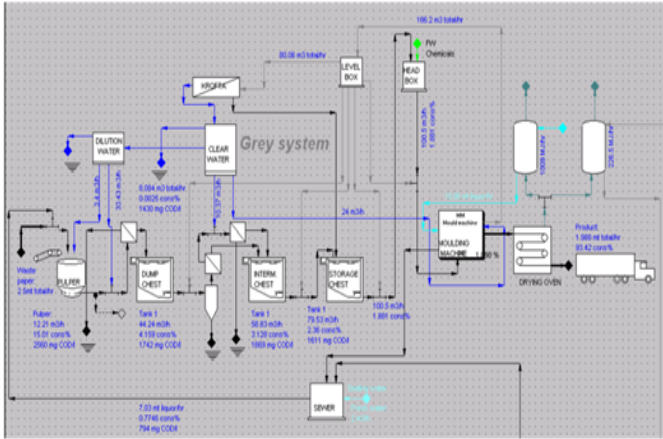

Illustration from IT tool for water mapping in industry

- Recommendations for choice of technology (for example, water quality upgrades of a process stream)
- Participation in testing of selected technologies and recommendations as to the final choice
- Monitoring and reporting of the impact of cleaner production measures
- Assistance in negotiations with the authorities, including issues such as the need for meeting demands for 'Best Available Technology'

SPECIAL COMPETENCIES

We make use of 'state-of-the-art' IT tools to visualise flows of water, energy and chemicals in production processes, and for scenario preparation and modelling. We've developed in-house mass balance tools, but we also apply commercially available tools for specific industrial sectors.

Characterisation of process water and wastewater streams is often the key to a successful outcome of cleaner production projects. We have laboratory facilities at our disposal for advanced characterisation. This includes set-ups for chemical and biological treatability studies.

Through participation in numerous national and international research, development and demonstration projects, we've gained experience in most aspects of the area of cleaner production within a number of specific industrial sectors. We've also built up a large network of researchers as well as technology suppliers, which enables us to bring the latest scientific knowledge to a project, and to discuss and

Contact: Mette Tjener Andersson - mta@dhigroup.com
 For more information visit: www.dhigroup.com

recommend practical technical solutions.

BENEFITS FOR THE INDUSTRY

Saving water, energy and chemicals may result in direct cost savings in terms of a smaller bill for purchase of these resources. However, typical benefits from cleaner production measures include:

- less dependency on access to water resources
- decreased cost of wastewater discharge
- reduced environmental impact

These benefits are just as important as a direct reduction in production costs.

Finally, the concept of Corporate Social Responsibility (CSR) has gained momentum in recent years and seems, especially for large industrial enterprises to be a major motivational factor for initiating green initiatives as saving energy and water.

THE INDUSTRY AND DHI

We work towards cleaner production projects at all levels – from single production processes over complete factory solutions to symbiotic solutions at major industrial sites.



Many industries have to meet stricter environmental regulations and will have to invest to enable the required water savings. Photo: iStock © Lisa-Blue

Our clients belong to a wide range of industrial sectors, including:

- chemicals
- paper
- food processing and ingredients
- dietary supplements
- pharmaceuticals
- biotechnology
- metal processing
- textile and textile services